



**DRAFT AGENDA**  
**MesoAmerican - Caribbean Sea Hydrographic Commission**  
**ELECTRONIC CHART WORKING GROUP MEETING**  
**Cartagena de Indias, Colombia**  
**(August 30-31, 2004)**

**DAY 1**

- |       |  |                      |
|-------|--|----------------------|
| 8:30  | Welcome, Introductions, General Announcements  | K. Ries/R. Ponce     |
|       | <ul style="list-style-type: none"><li>• Approval of the Agenda</li><li>• Approval of minutes from previous meeting</li></ul>                       |                      |
| 9:30  | Status of Task Groups 1 and 2 Activities   | D. Fuentes           |
|       | <u>Task Group 1</u>  |                      |
|       | <ul style="list-style-type: none"><li>• Capacity Building efforts</li><li>• Gulf of Honduras</li><li>• Funding</li></ul>                           |                      |
|       | <u>Task Group 2</u>  | F. Angli             |
|       | <ul style="list-style-type: none"><li>• Chart Production Review/Updates</li><li>• Proposal for Production of Small-scale INT Charts/ENCs</li></ul> |                      |
| 10:00 | Break  |                      |
| 10:20 | Task Group Break-out sessions  | D. Fuentes/ F. Angli |
| 12:30 | Lunch  |                      |
| 14:00 | Task Group Break-out sessions  | D. Fuentes/ F. Angli |
| 15:30 | Break  |                      |
| 16:00 | Reports back to Plenary  | D. Fuentes/ F. Angli |
| 17:00 | Next Steps/including next meeting  | K. Ries/R. Ponce     |
| 17:30 | Adjourn for Day 1  |                      |

## **DAY 2**

9:00 **Workshop I: Hydrographic Services and Private Companies** R. Ponce

- Lessons Learned
- Past Experiences
- Things to consider when dealing with Private Companies
- Recommendations

12:00 Lunch

13:30 **Workshop II: Presentations by Private Companies** Private Companies TBD

- Types of assistance/services available
- Examples of Arrangements

16:00 Adjourn

Meso-American Caribbean Sea Hydrographic Commission  
Electronic Chart Working Group

**Task Group 1 – Meso-American Pilot Project**

**Interim Progress Report**

Goal: Improve capacity building of coastal state hydrographic offices in a defined area by conducting a pilot project in the Gulf of Honduras (GoH) that demonstrates the benefits of nautical chart production as a means to improve safety of navigation, efficient inter-modal transportation, natural resource management, and growth in core economic sectors of the regional economies (e.g., tourism, cruise ship industry).

The primary objectives of the GoH Pilot Project (Belize, Honduras, and Guatemala) are the protection of the marine environment and contributing to the region's sustainable economic growth. However, the project proposal now includes a hydrographic component to demonstrate that hydrography can be used for purposes that extend beyond safety of navigation. The hydrographic component has several stages, including conducting hydrographic surveys, data acquisition/management, paper nautical chart/RNC/ENC production, and development of Marine Information Objects (MIOs) associated with marine environmental protection. It is also intended that this pilot project will build partnerships and establish collaborative arrangements under regional development and environmental projects that are being funded by organizations such as the World Bank, Global Environment Facility (GEF), InterAmerican Development Bank (IADB).

Actions to Date

The GOH project has been submitted to the GEF Council for approval. If granted, the five-year GoH Project is expected to become operational in late 2004. Using existing hydrographic survey data for priority ports in Belize and Honduras, it is hoped that ENC production can begin during the first year of the project. Surveying and expanding the ENC coverage for Guatemala priority ports is planned during the third year. It is expected that the GoH Project will act as a catalyst to enable the production of paper charts, RNCs and ENCs for the Gulf of Honduras region at 1:50,000 scale.

Following the 24 March 2003 MACHC meeting in Biloxi, Mississippi, TG 1 members met with representatives of the Global Environmental Facility (GEF) and the InterAmerican Development Bank (IADB). More recently, TG 1 members attended the final meeting for the preparation of the GEF/IADB GOH project proposal on October 9-10, 2003 in Tegucigalpa, Honduras. In addition to representing MACHC during the project negotiations, TG 1 Team members organized and delivered a special information session. This session had three objectives:

- 1) Inform the meeting's participants about the role of hydrography in providing for alternative products and services in support of environmental protection and natural resource management.
- 2) Explain the MACHC-ECWG involvement in the project preparation
- 3) Open a dialogue about the implementation on the project's hydrographic component and institutional capacity-building elements. In this regard, discussions were held with representatives from the project countries regarding the benefits of ENC development and hydrographic institutional capacity building in terms of achieving other national/regional objectives (e.g., marine environmental protection).

[Note: The following is an extract from the GOH Project Brief that contains the hydrographic component]

---

***Component 3: Enhancing navigational safety in shipping lane.***

**Activities:**

The activities in this component focus on preventing accidental groundings and discharges from maritime transport operations, and developing the infrastructure and capacity to address such spills if they occur. Activities under this component focus on improving the hydrographic and oceanographic cooperation in the region in order to both prevent and prepare for potential groundings and spills in the Gulf related to maritime transport operations. Policy and legislative interventions will be defined, on national and regional bases. New technologies will be demonstrated in order to aid in the prevention of accidents and contingency plans will be developed for addressing accidents. These two demonstration projects will be developed and agreed during the full project, with a focus on replicability and incorporation into the SAP.

3.6 - Building on the initial assessment / gap analysis of regional hydrographic capabilities of the Meso-American and Caribbean Sea Hydrographic Commission (MACHC), hold a high-level workshop to address institutional arrangements for regional capacity building. Participants should include senior, decision-making representatives from each country's national interministerial hydrographic coordination mechanism (Commission, Steering Group, etc.), regional organizations such as COCATRAM, MACHC and other key players. Such a workshop should 1) explore alternatives for regional cooperation under the scope of the project, and 2) decide on a common approach, including political arrangements that will effectively build regional capacity while reducing costs by utilizing common assets.

- Each country establishes an interministerial mechanism (Commission, Committee, Steering Group, etc.) with representatives from relevant government ministries (including the National Geographic Institutes) and private sector entities to assess, organize and coordinate national efforts related to hydrographic data collection, processing, production and dissemination.
- Each country's interministerial coordination mechanism to reach a consensus on what capabilities, products and services it could potentially provide in support of regional hydrographic initiatives, including identifying and providing access to existing hydrographic data.

3.7 - Develop and implement a training/demonstration program for national and regional entities in hydrography to improve technical capacity.

- Building on the outcomes of the above-listed high level regional workshop, obtain sustainable access to training, expertise and equipment (both hardware and software) required for hydrographic product and service needs, hydrographic data collection, processing, analysis, paper and electronic chart production and distribution, and demonstrate in each country the application of this capacity for purposes of hydrographic charting and other requirements of the project, in priority areas such as navigation channels, high-value environmental resource areas, etc.
- Provide training on hydrographic data processing, archiving and production of electronic navigational charts.
- Provide training on how to format hydrographic data so that it can be integrated into the project data and information management system (including GIS) and used for non-navigation purposes (such as coral reef mapping, coastal zone management, etc.)

3.8 - Identify and conduct two demonstration pilot activities related to improved navigation safety and marine environmental protection. Examples include improved navigational products and services (e.g., producing electronic navigational charts for key ports and piloting development of environmental marine electronic objects) and regional vessel tracking capabilities, and improved processes for removal, transport, and treatment of chemical wastes (including oil, solid waste and water).

---

Meso-American Caribbean Sea Hydrographic Commission  
Electronic Chart Working Group

**Task Group 2 – ENC Production and Distribution**

Dear Colleagues:

The purpose of this message to update the full membership of the Meso-American Caribbean Sea Hydrographic Commission (MACHC) Electronic Chart Working Group (ECWG) on the progress to date of the Task Group 2 (ENC Production and Distribution) that I have had the pleasure to chair.

I would first like to inform you that I have been transferred to a new assignment within the Mexican Navy and will no longer be able to serve on the ECWG or as Chair of TG 2. However, my knowledgeable and enthusiastic colleague, Captain Fernando F. Angli, new Director of Hydrography is assuming my position and he will take my former responsibilities. Please send any future communications regarding both TG2 activities and the MACHC INT Chart Project. He can be reached at: [digadhicar@semar.gob.mx](mailto:digadhicar@semar.gob.mx) . Below please find the summary of our progress to date:

TG2 Goal: Facilitate the production and distribution of ENC data for major ports and shipping routes within the MACHC region. Promote the use of ENC data by major shipping companies and cruise lines thereby contributing to safety of navigation, improved efficiency of maritime transportation, and marine environmental protection.

Actions to Date

Based on the Minutes of the 24 March 2003 ECWG meeting and corresponding Action List (Annex B), the following progress has been made to date.

1. INT Chart Project – All participants to the meeting were sent a CD containing the proposed regional INT chart scheme and table (matrix) of assignments. This information is also available on the MACHC-ECWG web page. The matrix has been updated to reflect the responses so far regarding (Rafael, we need the updates clarified from the matrix Cornelio sent me, Lee is willing to update the entire matrix with all available information) and has been posted (or will be?) to the MACHC website (add address):
  - a. who the primary point of contact for INT matters
  - b. what countries will take responsibility for charts still lacking sponsors
  - c. dates as to when those charts would be produced and become available

Member states are encouraged to communicate this information as soon as possible to Lee Alexander, ECWG Technical Coordinator at: (add Lee's e-mail address).

2.a ENC Production - Relatively little follow-on information has been received from Member States regarding the Priority List of Ports and Routes agreed to at the 24 March 2004 meeting. Although there was general agreement on what ports and routes needs to be produced,

it is less well known how this will be performed (e.g., digitizing existing paper charts), and who will do it. One possible approach to producing large-scale ENC's has been proposed by cruise line shipping companies. Some have expressed willingness to fund the cost of producing IHO S-57 ENC data for key harbours/ports that have been recently dredged/surveyed. Their interest is to ensure safety-of-navigation for their vessels. In turn, they would be willing to turn this data over to the hydrographic office or port authority if it were to be issued as official ENC's. I will have some research done in advance of our next meeting regarding the regional cruise line shipping companies and identification of important ports and routes where there is currently a demand for ENC data and services. At our next meeting, I suggest that our Task Group then see how and where this information overlaps with the priorities we have established and discuss the desirability of such partnerships with the private sector to advance our objectives.

2.b As the Chair of both this Task Group and the INT Chart Working Group, it occurs to me that a logical approach to producing small-scale ENC's (1:1,00,000 scale) for the MACHC region would be to base it on the INT Chart scheme. Once the paper charts are produced, it would be a relatively easy to produce ENC's from them. This would also be consistent with the plans of the IHO World Electronic Navigation Database (WEND) Committee plans. I am in the process of communicating with the producers of the small-scale INT charts to determine if and how soon ENC's could be produced from them and will provide an update at our next meeting.

2.c ENC Distribution – Relatively little progress has been made toward the establishment of regional ENC distribution and services, as the initial focus has been on ENC production. However, our group does need to begin discussions on distribution methods, particularly if the smallest scale INT charts will be produced as ENC's over the next year. A discussion paper on options will be developed and distributed to the ECWG in advance of our next meeting for the group's consideration.

(Lee—would you be willing to develop a proposal listing options for making these ENC's available, including making them freely available via the MACHC website? Or is the whole section premature, given that we don't even have the products yet? We can discuss more....)

4. IHO World ENC/WEND Task Group – The 7<sup>th</sup> WEND meeting commissioned a Task Group to formulate a plan to stimulate ENC production and accelerate world-wide coverage of ENC's. This Task Group has requested information regarding ENC's from all the IHO Regional Commissions. Based on the information generated from our Task Group, a response to WEND Letter No 2/2003 was submitted to IHB. Specifically, this included a prioritized list of shipping routes needing ENC coverage; small-scale ENC coverage for the entire region; recommendations for bi-lateral assistance projects; and, proposals to increase ENC production, quality and consistency. Copies of the response can be found on the MACHC website.



(Draft Version 1)

**Point Paper #1 – Production of International ENC's**

5 December 2003

Background

Lack of worldwide ENC coverage continues to be a nagging problem. Most HOs have been unable to produce sufficient quantities of data to meet the specifications that IHO developed (i.e., S-57 ENC Product Specification). This pertains to ENC data at all scale ranges required to for a navigational purposes of a ship' voyage (e.g., General, Ocean, Coastal, Approach, and Harbor)

Depending on how determined, 70-80% of the World's oceans are considered international waters. In [yr?], IHO established an IHO INT Chart Scheme [ref?]. As called for in Section A-101.1: "*The aim of the international chart concept is to facilitate the provision of minimum sets of charts suitable for the navigational requirements of international (foreign-going) shipping.*" The INT charts are small-scale paper nautical charts that are produced under cooperative agreement by HOs in a particular region (e.g., MACHC). As listed in the INT Scheme, the scale range of these paper nautical charts is:

- General – less than 1:1,500,00
- Passage – 1:1,500,000 – 1:375,000
- Coastal - 1:375,000 – 1:130,000

At the March 2003 Meeting of the MACHC-ECWG, an INT Chart Scheme was proposed for the Caribbean Sea – Gulf of Mexico Region

Recommendation: The INT Chart Scheme for the Caribbean Sea – Gulf of Mexico region should be the basis to produce official, small-scale ENC data for international waters.

Steps:

1. Determine the status of INT Chart Scheme that was introduced at the March 2003 meeting of the MACHC-ECWG.
2. Compile a listing (and coverage map) of:
  - a. what has been produced (scales and coverage); by who?
  - b. what is planned; who will do it?
  - c. where do gaps occur?
3. Obtain current/new INT paper charts; assist those MS that are experiencing difficulty or have no capability to produce in the near future
4. Identify private companies/organizations willing to produce International ENC's (from existing INT Paper Nautical Charts) on behalf of the MACHC.
5. Once produced, the International ENC's would undergo a validation/QA process performed by CCOM-JHC at UNH prior to official release.
6. Following validation, the International ENC's would be posted on the IHO and MACHC websites and would be available free-of-charge as a "service" to ECDIS/ECS manufacturers, chart producers/distributors, and the maritime shipping industry.

**International Hydrographic  
Organization**



**MesoAmerican-Caribbean Sea  
Hydrographic Commission**

Benefits

1. MACHC would be viewed as both facilitating action and accomplishing tangible results that benefit MACHC Member States, IHO, charting industry and maritime user groups
2. Involves synergistic cooperation between IHO and "Industry Stakeholders" (mutually beneficial)
3. Provides "official ENC" coverage for General, Ocean and Coastal routes within MACHC region
4. Encourages larger-scale ENC production for coastal, approach and harbor areas
5. Does not require funding from member states, IHO, or 3<sup>rd</sup> party to accomplish
6. Would help facilitate establishment of RENC based on IHO WEND concept
7. Encourage the use of IMO-compliant ECDIS (type-approved) for SOLAS vessels in region.

Obstacles

1. Reluctance of IHO, MACHC and M.S. to work cooperatively with "Industry"
2. Skepticism by Industry toward IHO (viewed as impediment)
3. Some in Industry will want to be paid for producing International ENCs
4. Some M.S. will want to derive revenue from sale of ENCs produced from INT Charts
5. Micro-management by IHO, MACHC, or former colonial nations
6. Concern about liability for accuracy and completeness
7. Who should perform validation (e.g., UNH or PAIGH)
8. Belief that inaction is a safe strategy since it avoids commitment or risk

---

Prepared by:  
Dr. Lee Alexander  
Technical Coordinator, MACHC-ECWG

## ENC Distribution Options Based on WEND

### Introduction

The electronic chart is a new technology capable of continuously determining a vessel's position in relation to land, charted objects, aids-to-navigation, and unseen hazards. As a real-time navigation system, electronic charting provides significant benefits in terms of improvements in navigation safety, efficiency of maritime transportation, and marine environmental protection.

In terms of system components, features and functional capability, there are two basic types of electronic charts. The most advanced form is an Electronic Chart Display and Information System (ECDIS). All other types can be regarded, generically, as Electronic Chart Systems (ECS). For an electronic chart to be considered an ECDIS, it must comply with the Performance Standards for ECDIS formally adopted by the International Maritime Organization (IMO) in November 1995 [1]. In particular, an ECDIS must use official Electronic Navigational Chart (ENC) data in order to meet the chart carriage requirements contained in regulation V/19 of the 1974 SOLAS Convention as amended in 2000 [2]. IMO specifically requested that Member Governments have their National Hydrographic Offices (HOs) produce electronic navigational charts (ENCs) and the associated updating service as soon as possible, and to ensure that manufacturers conform to the performance standards when designing and producing electronic charting equipment.

### The WEND Concept

In an effort to facilitate the distribution and use of official ENC data, the Worldwide Electronic Navigational Chart Data Base (WEND) was established by the IHO in 1992 during the 14<sup>th</sup> International Hydrographic Conference. It was in response to a proposal by the Norwegian Hydrographic Service to establish a worldwide Electronic Chart Center (ECC). Rather than a single ENC distribution center, the WEND concept is based on a number of Regional ENC Coordinating Centers (RENCs) being established throughout the world [3]. Based on this approach, IHO Member States would cooperate to produce an integrated database containing ENCs from a number of Hydrographic Offices (HOs) within a particular region.

As outlined in Annexes 4-6 of the “Report of the Special Committee on WEND” [1], WEND is defined as:

- 1. A common worldwide network of ENC datasets, based on IHO standards, designed to specifically meet the needs of international maritime traffic using ECDIS, which conforms to IMO Performance Standards.*
- 2. The System will utilize HO national ENC datasets, which are integrated and may be distributed and updated through regional centres.*
- 3. WEND represents an IHO system based on the co-operation of participating Member States.*

Following its adoption by IHO Member States, the Special Committee on WEND became a regular IHO committee tasked with implementing the WEND concept. The IHO WEND Committee has met annually since 1994.

The WEND Concept includes two primary components:

1. A set of principles for cooperation (the so-called WEND Principles)
2. A conceptual model (see Figure 1) for its data flow and organizational relationships

**Figure 1 – The conceptual WEND model (after Hecht 2002).**

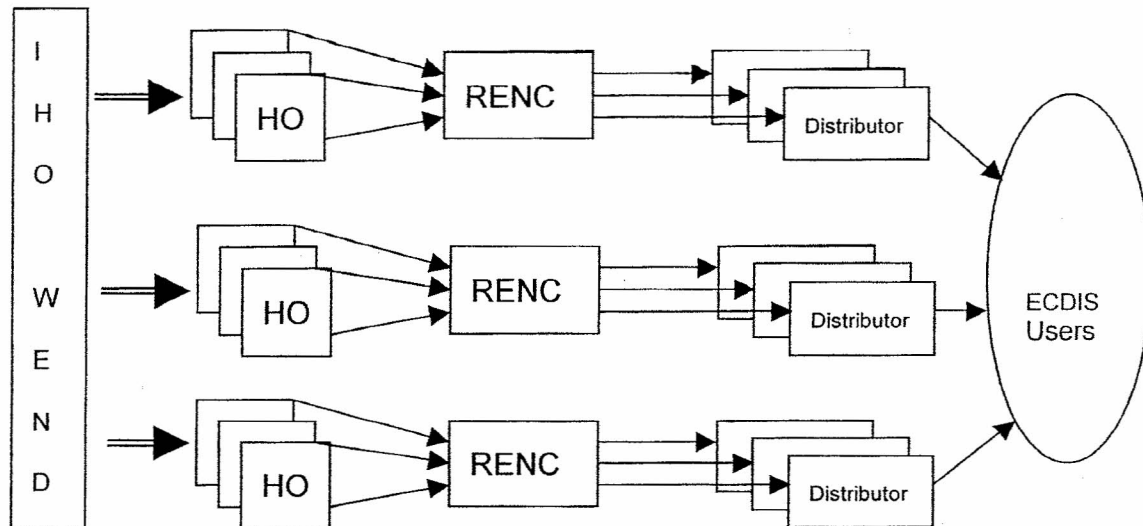

### WEND Principles

As discussed in a recent article, the WEND Principles fall into two primary groups [4].

1. Principles regulating internal, mutual relationships between HO's related to:
  - ownership and responsibility
  - cooperation and coordination
  - reimbursement and financial arrangements
  - assistance and training
2. Principles defining the core business to be conducted under the umbrella of WEND, this includes:
  - standards and quality management
  - distribution
  - updating

Ideally, the WEND Principles should:

- encourage ENC production in areas without adequate coverage,
- avoid duplication of ENC production (i.e., overlapping areas), and
- facilitate ENC implementation through cooperation between producing nations for data production, sharing, and distribution.

The WEND principles do not cover the distribution of paper charts or Raster Navigational Charts (RNC). However, for most parts of the world, particularly those outside the high-traffic ports and waterways (e.g., major European ports, Singapore, and Hong Kong) it will not be possible to

use ECDIS for navigation without relying on some RNC data, commercial electronic chart data, or paper charts for a significant portion of a ship's voyage.

## **RENC**

The WEND Concept does not provide a specific definition of a Regional ENC Center (RENC). Instead, it refers to a 'regional center' as a means for data distribution. On the other hand, as shown in the conceptual WEND Schema (Figure 1), a RENC can be whatever two or more cooperating HOs decide to establish in order to facilitate ENC distribution and services [2]. Originally, this was expected to be a physical center or facility in proximity to HOs in a particular region. However, as pointed out by a former IHO Director, "modern data communication has no boundaries and in the servicing of a database, the need to consider adjacency may be less important the need to service customers [4]."

## **RENC Models**

Two RENC models have emerged so far:

1. ENC Coordinating Center (ECC)
2. Virtual RENC (VRENC).

However, some countries have made a purposeful decision not to form or join in any type of RENC, and are acting independently (i.e., go-it-alone).

### **1. ENC Coordinating Center**

Under this model, a dedicated staff is employed full-time to operate at an established facility (e.g., a bureau) on behalf of cooperating HO's. Each cooperating HO provides its ENC data to the ECC, who ensures that the products are consistent with the data received from other contributing countries. The ECC also acts as a single wholesaler of the collective set of ENC data that it holds. The only ECC to be established in this way was *PRIMAR*<sup>TM</sup> (formerly known as the European ENC Coordinating Centre). *PRIMAR*<sup>TM</sup> was established in 1996, and funded principally by the Norwegian Hydrographic Service and the UK Hydrographic Office. For the 12 participating HOs (Belgium, Denmark, Finland, France, Germany, The Netherlands, Norway, Poland, Portugal, Spain, Sweden and the United Kingdom), services provided included ENC production, data format validation, data integrity and access control (encryption), marketing, wholesale distribution, and collection and distribution of royalties. *PRIMAR*<sup>TM</sup> also offered an official ENC service to mariners via its own appointed distributor network [6].

In 2001, it became clear that for *PRIMAR*<sup>TM</sup>, the operating costs were higher and revenue expectations were lower than expected. As such, in late 2001 *PRIMAR*<sup>TM</sup> split into two separate RENCs: Norwegian Hydrographic Service RENC and the UK International Centre for ENCs.

### **NHS RENC**

On 1 April 2002, the Norwegian Hydrographic Service (NHS) re-established a RENC in Stravanger, Norway that included five cooperating HOs from the former *PRIMAR*<sup>TM</sup>: Denmark, Finland, France, Norway and Sweden. As described in the Executive Summary of the Operational Proposal [7], the NHS RENC is a simplified version of RENC service previously provided by *PRIMAR*<sup>TM</sup>. To be operated as fit-for purpose and a non-profit organization, it will maintain all key elements of the former *PRIMAR*<sup>TM</sup> functionality, but at considerably lower cost.

Bilateral agreements between cooperating HOs and NHS are the basis for the operation and provision of the relevant RENC cooperation, responsibilities, and services. Continued development of the NHS RENC operation and strategy will be through consultation with the participating HOs.

The NHS RENC intends to increase and maximise utilisation of ENC's by engaging in non-exclusive strategic alliances with authorised distributors, and by establishing comprehensive distribution mechanisms based on market knowledge. NHS RENC will focus on active distributors in order to provide an efficient and effective service, aiming at global coverage. Continued operation of the *PRIMAR*<sup>™</sup> security service will be used to support existing ENC distribution. Cooperating HOs and NHS RENC will collectively ensure a harmonised and validated ENC product database complying with all relevant ENC quality standards. The NHS RENC service is based on a cost recovery model from 2002. All sales revenues will be returned to each national HO, or alternatively, the NHS RENC could retain the sales income to offset HO financial requirements.

The NHS RENC will cooperate with other RENCs in accordance with WEND principles, and supports the Virtual RENC (VRENC) concept that enables other HOs worldwide to join the NHS RENC with full control and access to their national product database.

Additional information may be obtained by contacting:

Kjell Biekevold, Marketing Director (kjell.birkevold@statkart.no)  
Norwegian Hydrographic Service (www.statkart.no/sksk)

Rune Holst Johnsen, Marketing Manager (rune.johnsen@primar.org)  
*PRIMAR*<sup>™</sup> Stavanger (www.primar.org/stvanger)

#### International Centre for ENC's (IC-ENC)

On 1 July 2002, the United Kingdom Hydrographic Office (UKHO) and five other European HOs (Belgium, Germany, The Netherlands, Portugal, and Spain) established the International Centre for ENC's (IC-ENC) as a successor to *PRIMAR*<sup>™</sup>. Similar to the former *PRIMAR*<sup>™</sup>, IC-ENC is modelled around the concept of an RENC as envisaged under the IHO WEND concept. As described in the IC-ENC "A Guide to the New RENC" [8], IC-ENC will operate on a not-for-profit basis using established distribution mechanisms. IEC will follow the original *PRIMAR*<sup>™</sup> model by continuing to validate each ENC before releasing it into its database. It will also use a deferred payment system to recover its costs, avoiding the need for cooperating HOs to invest new money in IC-ENC. However, unlike the former *PRIMAR*<sup>™</sup>, IC-ENC does not operate an end-user service. Instead it will take advantage of the expertise and experience of existing service providers, allowing these companies to develop their own tailored services based on the ENC data. As such it will be the Value-Added Resellers (VARs) that will actually bring the ENC's to the market. In concept, this should reduce the cost and technical complexities of IC-ENC, while at the same time maximizing the availability of the ENC's.

As the operator of IC-ENC, it is the UKHO who establishes the necessary Bilateral Agreement with each cooperating HO. This arrangement sets out the principles of IC-ENC, outlines the provision of services, and defines relevant operating procedures and financial arrangements. The Bilateral Agreement can either be a standalone document or an extension to an existing arrangement. The IC-ENC seeks to establish the widest coverage of ENC's that is possible. As such, membership in IC-ENC is open to any national HO wishing to join and sign a Bilateral Agreement with the UKHO.

Additional information may be obtained by contacting:

Phil Wainwright (e-mail: [phil.wainwright@ic-enc.org](mailto:phil.wainwright@ic-enc.org))

IC-ENC ([www.ic-enc.org](http://www.ic-enc.org))

## 2. Virtual RENC

Under this model, there are no permanent staff or a centralised organization. Regional ENC producer nations agree on production standards, areas of coverage, general distribution principles, and related matters to ensure that ENCs across a region are uniform and consistent. It is then left to each ENC producer to ensure that its ENCs meet the agreed requirements of the Virtual RENC (VRENC). Individual HO's are also left to arrange their own marketing and distribution arrangements for their ENCs.

The Mediterranean and Black Sea VRENC is in an advanced stage of implementation, but is as yet operational [9]. Its regional base is the countries of the Mediterranean and Black Sea Regional Hydrographic Commission. Other IHO Regional Hydrographic Commissions have expressed interest in this approach and may adopt a similar model.

### Go-It-Alone

Some countries have decided that they do not need to join or establish either a RENC or VRENC. This is the case for both the USA and Canada. Based on the discussions during the recent meetings of the IHO WEND Committee, some of the reasons include:

- there are no other regional ENC producers
- an HO wants to provide an integrated chart service (paper, RNC and ENC)
- an HO has produced so little data that RENC distribution is unwarranted
- an HO cannot come to satisfactory agreements with other HOs or RENCs
- some countries are large enough to become their own RENC

### Future of the RENC concept

If the WEND principles are to be followed, then a high level of coordination and cooperation between adjacent ENC producers must occur. As suggested at a recent IHO Workshop on ENCs [10], the choices to achieve this appear to be:

- to establish a bureau similar to:
  - a. Norwegian Hydrographic Service RENC (NHS RENC)
  - b. UK HO International Centre on ENCs (IC-ENC)
- to work through regional cooperation (the virtual RENC model)
- to observe all the IHO requirements but effectively produce and distribute ENCs without involving other HO's (i.e., be your own RENC)
- to develop new model(s) perhaps by involving industry more directly

### Other ENC Distribution-related Issues

#### Optional SENC Distribution of Official ENCs

At the 16<sup>th</sup> International Hydrographic Conference, a proposal was adopted that allows HOs to authorise the distribution of official ENC data in a SENC format [11]. This means that the

ENC would be converted into the SENC format used in an ECDIS before it was sold, rather than being converted in the ECDIS onboard the ship. As an optional arrangement to be exercised at the discretion of each HO, this would be in addition to (not instead of) official ENC distribution. Authorised SENC versions of ENC data would most likely be performed by an authorized SENC data distributor under the control of the RENC or the supplying HO. The SENC distributor would be supplied with a master copy of the ENC from which the SENC copies would be produced.

Some of the reasons expressed for allowing SENC delivery as an additional method of official data distribution include:

- ECDIS equipment manufacturers can be sure that ENC and SENC data's will operate correctly in their equipment
- use of official data will increase because SENC data can be used with both ECDIS and ECS systems.
- a SENC is by its very nature a secure data format that incorporates data integrity, access control and anti-piracy measures.

A number of IHO Member States do not support SENC delivery. Their reasons include:

- certain commercial ECDIS manufacturers will have an advantage over others
- how can SENC distributors assure HO's that the SENC data will be authentic and unmodified?
- SENC distributors may add their own data to the SENC
- ENC and SENC alternative distribution formats will confuse mariners

#### Production of "Small-Scale" ENCs

The WEND Principles make it quite clear that each HO should be responsible for the production of ENCs covering its "waters of national jurisdiction". In this regard, most HO's have concentrated on producing "larger scale" ENCs of their ports, coastal areas, or major shipping routes. These generally occur within national jurisdiction or have been agreed through bi-lateral arrangements between adjacent nations. Agreement over production boundaries and access to data has generally been guided by following the long-standing practices for paper charts.

The issue of who will provide ENC coverage of international waters and waters beyond national maritime boundaries and the EEZ has been difficult to resolve. Australia and France have proposed that "small-scale" ENCs should follow similar arrangements to the production of paper INT charts. ENCs corresponding to small-scale INT charts would be produced by the same HO that produces the paper INT chart. Agreed production boundaries would have no political delimitation significance. Furthermore, for the smallest scales, no royalties would be sought for the use of data from other HO's. However, this concept has not been put into practice.

## Looking to the Future

WEND was originally intended to have the status of an independent international organisation. However, it continues to operate as a Committee of the IHO. Since its establishment in 1994, the WEND Concept has resulted in the initial establishment of just one RENC for the Northern Europe region that in late 2001, sub-divided into two separate entities (NHS RENC and UKHO IC-ENC). No other RENCs have been established in other regions of the world.

Despite its limited success, the WEND Concept continues to be pursued through regional or bilateral cooperation arrangements between Hydrographic Offices in the IHO. The agreed concept defines the responsibilities and functions of HOs within a region necessary to develop, quality-approve, and issue the official ENC's for the use in ECDIS. This will also include the required updating services. Similar to what occurs for other types of nautical charting products and services, HOs will eventually need to be decided upon and establish a means for cooperation. A regional hydrographic commission within the IHO (e.g., the Caribbean – Gulf of Mexico Hydrographic Commission) would seem to be a logical place to start.

**Recommendation:** The CGMHC – EC Working Group should establish a Task Group to determine (or decide) which ENC distribution option would be most suitable for the HOs in the Caribbean – Gulf of Mexico Region.

---

## References

- [1] IMO Performance Standards for Electronic Chart Display and Information System (ECDIS), IMO Resolution A.817(19), November 1995. International Maritime Organization, London.
- [2] Adoption of Amendments to the International Convention for Safety of Life at Sea (SOLAS) 1974, Revision to *Chapter V – Safety of Navigation*, IMO Resolution MSC.99(73), December 2000. International Maritime Organization, London.
- [3] Report of Special Committee on WEND. IHO Circular Letter 27/1994.
- [4] Hecht, Horst. 2000. WEND and RENC: Keywords for IHO's Distribution System for ECDIS Data – An Evaluation of Terminology and Concept. *International Hydrographic Review*, Vol. 1, No. 1 (New Series), p. 81-84.
- [5] Kerr, A.J. 1996. International Perspectives on ECDIS, *International Hydrographic Review*, LXIII (1). Monaco.
- [6] Wainwright, P. 2000. The Implementation of the WEND Concept: The PRIMAR Experience. *International Hydrographic Review*, Vol. 1, No. 2 (New Series), p. 55-61.

- [7] “NHS RENC Operational Proposal,” v1.2 – Expanded. Norwegian Hydrographic Service, Stravanger, 4 April 2002. [[www.primar.org/stravanger](http://www.primar.org/stravanger)]
- [8] International Centre for ENC’s: A Guide to the New RENC”, October 2002, [[ic-enc.org](http://ic-enc.org)]
- [9] Status Report on Virtual RENC Development in the MBSHC Area”, Report to 6<sup>th</sup> WEND Committee Meeting, 18-19 May 2001, [WEND Paper WEND/6/12a].
- [10] Ward, R. 2002. WEND Issues and ECDIS Data Distribution. Proceedings *GEOMATICA 2002: IHO Workshop on ENC Production*, 18 February 2002, Havana, Cuba.
- [11] Technical Resolution A3.11 – ENC/SENC Distribution Option, XVIth International Hydrographic Conference, 14-19 April 2002, Paper CONF.16/WP.3 Add2.

---

Prepared by:  
Dr. Lee Alexander  
Center for Coastal and Ocean Mapping – Joint Hydrographic Center  
University of New Hampshire  
Durham, New Hampshire USA  
[lee.alexander@unh.edu](mailto:lee.alexander@unh.edu)